

AWAC 2D

HORIZONTAL CURRENT PROFILING



CURRENT AND WAVE MEASUREMENTS IN THE OCEAN, LAKE AND LABORATORY



Nortek AS
Vangkroken 2
1351 Rud, Norway
Tel: +47 6717 4500
Fax: +47 6713 6770
E-mail: inquiry@nortek.no



www.nortek-as.com
True innovation makes a difference

AWAC 2D

HORIZONTAL CURRENT PROFILING



Vessel transit in areas with strong currents can be both difficult and dangerous, especially when large waves or gusty wind conditions are present. Nortek offers a 2D current profiler that measures currents up to 100m across channels to improve navigational safety. This current direction can be resolved into a component along- and cross-channel.

Ideal Real-Time Monitoring Solution

- ✓ Large transducers, which offer narrower beams that reduce interference from the surface or channel bottom.
- ✓ Compact transducer head, which may be mounted to a piling or seawall.
- ✓ Non-corrosive materials only (exclusively).
- ✓ Meticulously developed online components, including titanium connectors and a tough polyurethane cable.
- ✓ Longer maintenance intervals with anti-fouling paint and regulated power supplies.
- ✓ Easy to integrate into larger networks of sensors and data collection systems.

Nortek 2D current profilers are NOAA PORTS approved and compatible.

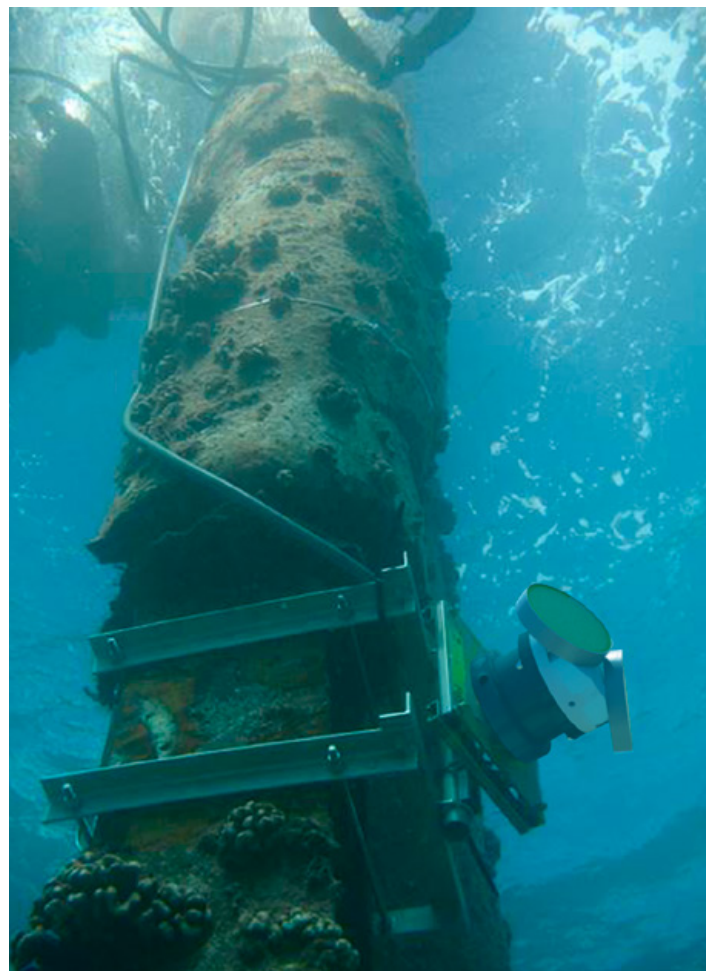
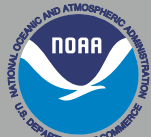

Horizontal Profiling Range Considerations

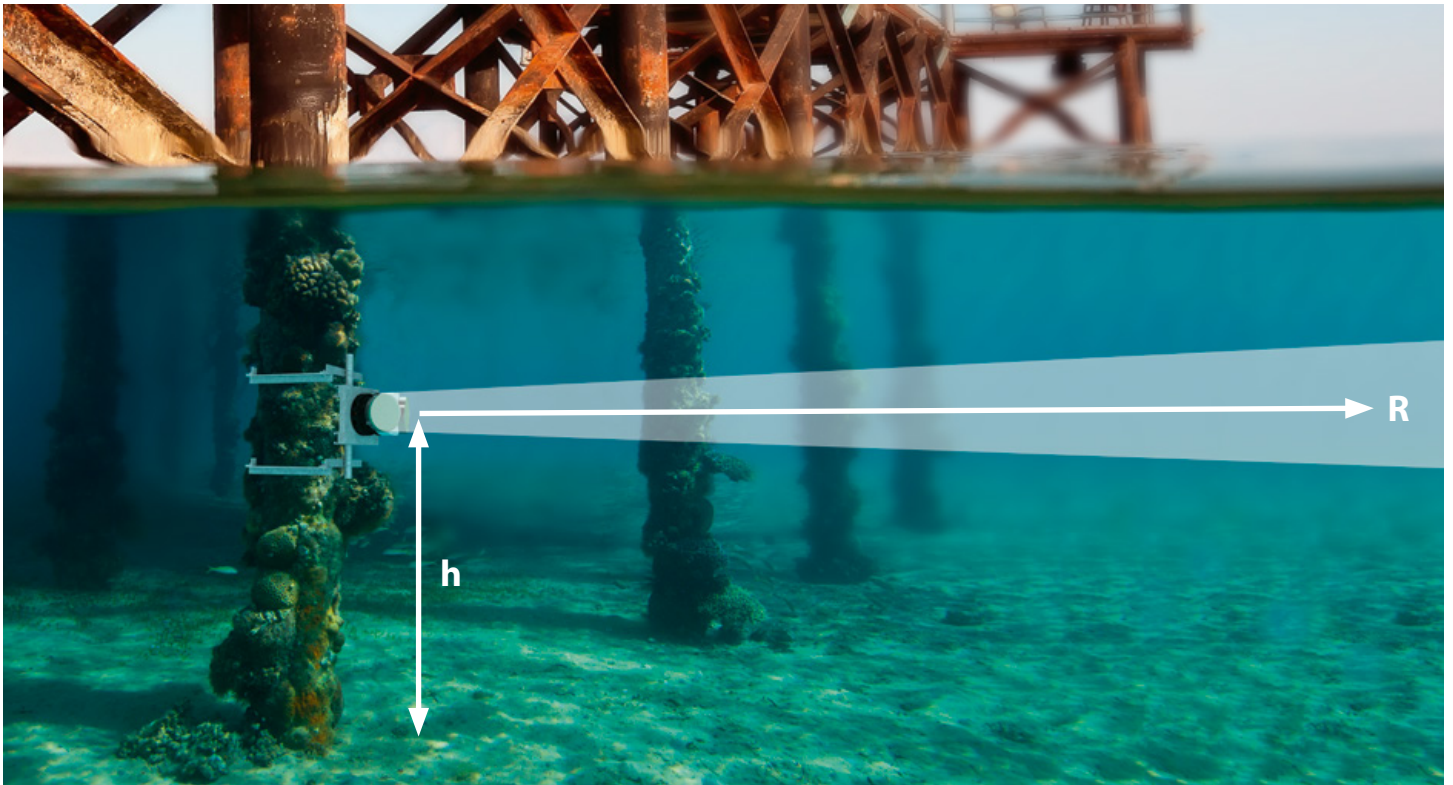

In shallow water, the echo from the bottom or surface can dominate the return from the water column. The echo from the bottom will bias the velocity toward zero because the bottom is not moving. The risk of getting a strong echo from the bottom increases as the acoustic energy pulse moves

further away from the instrument, therefore impacting range. The maximum profiling range, R , can be estimated as $R < 15 * h$, where h is the distance from the instrument to the bottom. It is advised that the instrument be mounted $2/3$ of the water depth from the bottom for best range.

AOS - Autonomous Online System



In areas with little infrastructure or no power supply, the 2D profiler can be integrated with the Nortek Autonomous Online System (AOS). This shore-mounted interface unit collects data from the 2D profiler, transfers the data to a server over Iridium satellites, and displays the data on a hosted website.

The data display is accessible to any AOS user with a connection to the Internet.

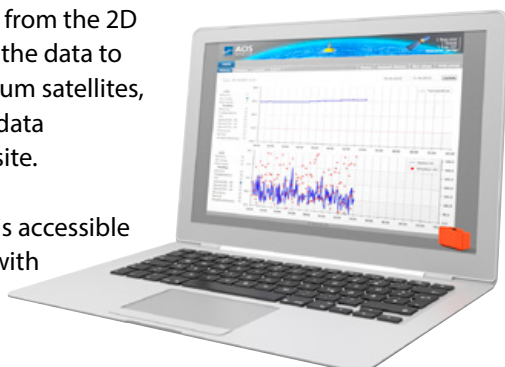

Technical Specifications

System	
Frequency:	400kHz
Beam opening angle:	1.7 degrees
Range:	100-130m*
Cell sizes:	1-8m
Number of cells:	Typically 20-40, max 128
Max output rate:	1Hz
*) depending on scatter conditions and depth	
Sensors	
Temperature:	Thermistor embedded in housing
Range:	-4 degrees C to 40 degrees C
Accuracy/Resolution:	0.1 degrees C/0.01 degrees C
Time constant:	<5min
Compass:	Magnetoresistive
Accuracy/Resolution:	2 degrees/0.1 degrees for tilt <15 degrees
Tilt:	Liquid level
Maximum Tilt:	30 degrees
Pressure:	Piezoresistive
Standard Range:	0-100m (others available on request)
Accuracy	0.5% of full scale, optional 0.1% of full scale
Resolution:	0.005% of full scale
Materials	
Standard:	Delrin and polyurethane plastics with titanium screws
Connectors	
Bulkhead (Impulse):	MCBH-2-FS, MCBH-8-FS, optional Birms 3K-7-OR-CA
Cable:	PMCIL-8-MP, Optional Birms
Data Recording	
Capacity:	9MB (standard), can upgrade to 4GB
Profile Record:	Ncellsx9 +120

Environmental	
Operating temperature:	-4 degrees C to 40 degrees C
Storage temperature:	-20 degrees C to 60 degrees C
Shock and vibration:	IEC 721-3-2
Depth rating:	300m
Dimensions	
	See drawing
Weight in air:	8,8kg
Weight in water	3,2kg
Data Communication	
I/O:	RS 232 or RS 422
Communication baud rate:	300-115200
Recorder download baud rate:	600/1200 kBaud for both RS232 and RS422
User control:	AWAC software or ActiveX controls, SeaState for online systems
Power	
DC Input:	9-18 VDC
Peak Current:	3A
Power Consumption:	Typical 1W when sampling
Transmit power:	1-30W, 3 adjustable levels
Sleep Consumption:	0.3 mW (RS232), 5 mW (RS422)
Real Time Clock	
Accuracy:	+1 min/year
Backup in absence of power:	1 year

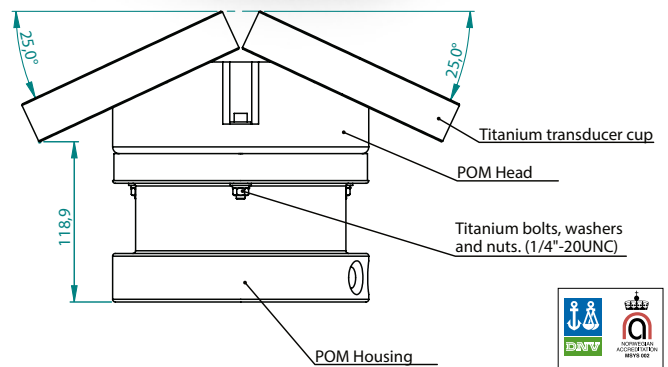
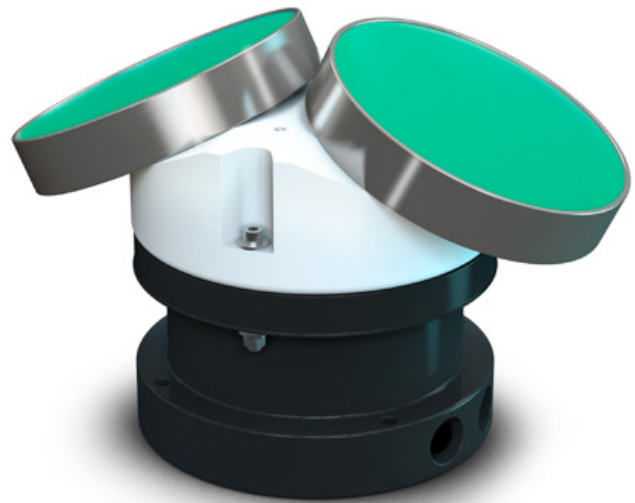
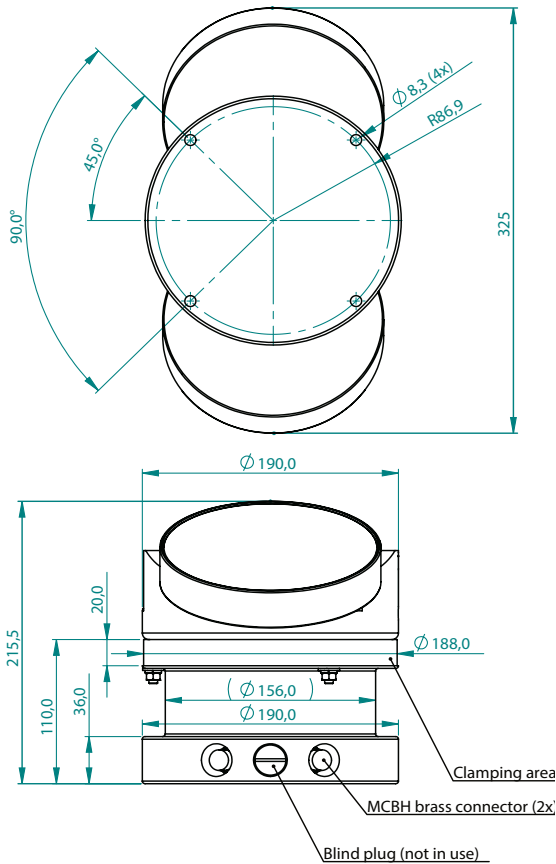

TS-010-en-102014

twitter.com/norteknews

facebook.com/Norteknews

youtube.com/Nortekinfo

NortekMed S.A.S.
ZI Toulon Est
67, Avenue Frédéric Joliot-Curie
BP 520, 83078 Toulon Cedex 09
Tel: +33 (0) 4 94 31 70 30
Fax: +33 (0) 4 94 31 25 49
E-mail: info@NortekMed.com

NortekUK
Tresanton House
Bramshott Court
Bramshott
Hants
GU30 7RG, UK
Tel: +44-1428 751 953
E-mail: inquiry@nortekuk.co.uk

NortekUSA
27 Drydock Avenue,
Mailbox 32, Boston,
MA 02210-2377
Tel: 617-206-5750
Fax: 617-275-8955
E-mail: inquiry@nortekusa.com

青岛诺泰克测量设备有限公司
地址: 中国青岛香港西路05号
汇融广场 1302
邮编: 266071
Tel: 0532-85017570, 85017270
Fax: 0532-85017570
E-mail: inquiry@nortek.com.cn

Nortek B.V.
Schipholweg 333a
1171 PL Badhoevedorp
Nederland
Tel: +31 20 6543600
Fax: +31 20 6599830
email: info@nortek-bv.nl

Nortek Brasil
Av. Nilo Peçanha nº 50,
grupo 2910 - Centro - Rio de Janeiro -
RJ - Cep 20020-906.
Tel: +55 (21) 4126-5954
Cel: +55 (21) 85046798
E-Mail nortek@nortekbrasil.com.br